

NORMAN FILTER COMPANY, LLC

ISO 9001:2008 certified

AS9001:2004 certified

Introducing
the High Flow, High Pressure
4900 Series Filter

Flow

150 GPM flow rate

Pressures

- **8,000 PSIG** operating
- **12,000 PSIG** proof
- **32,000 PSIG** burst

20.2 in. high x 8.0 in. wide

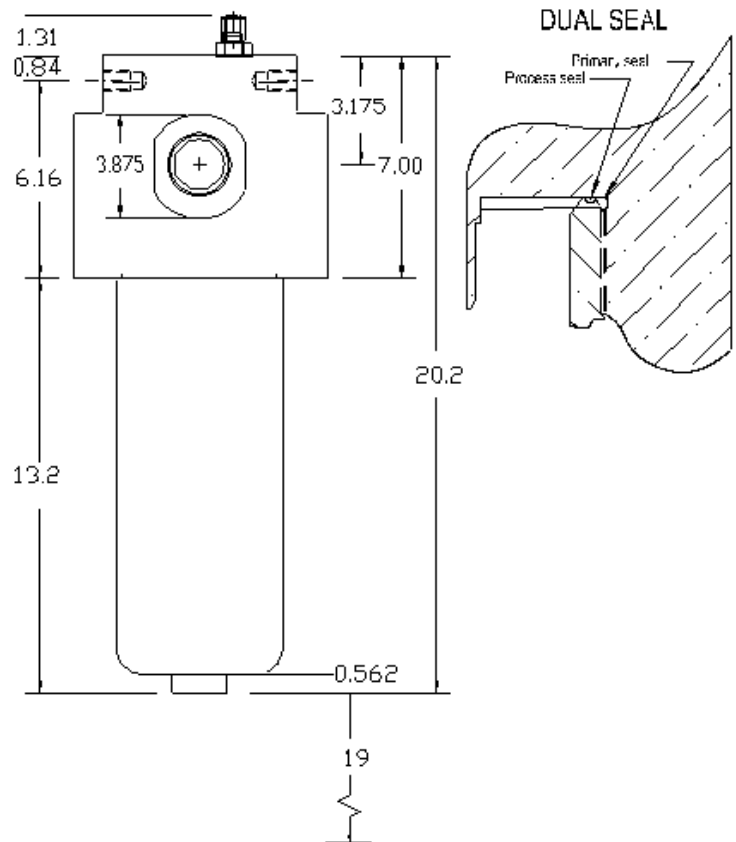
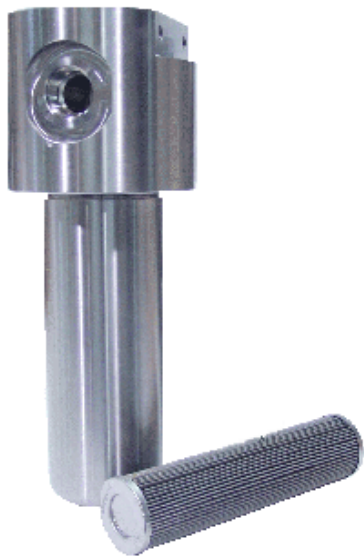

Housing Weight

316, 304 stainless steel

head 80 pounds

bowl 60 pounds

- **total 140 pounds** •

7075 aluminum

head 30 pounds

bowl 20 pounds

- **total 50 pounds** •

Process Temperature

stainless steel

maximum 300°F*

aluminum

maximum 200°F*

*or as limited by elastomer seals

For low or cryogenic temperature applications,
please contact Norman Filter Company.

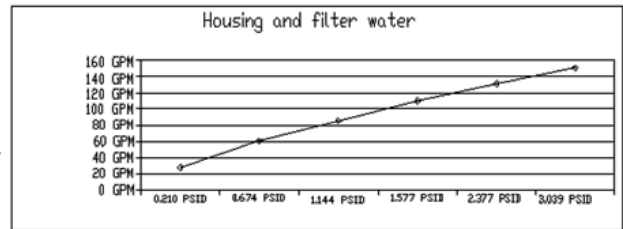
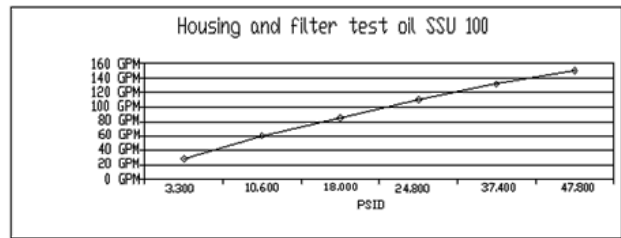
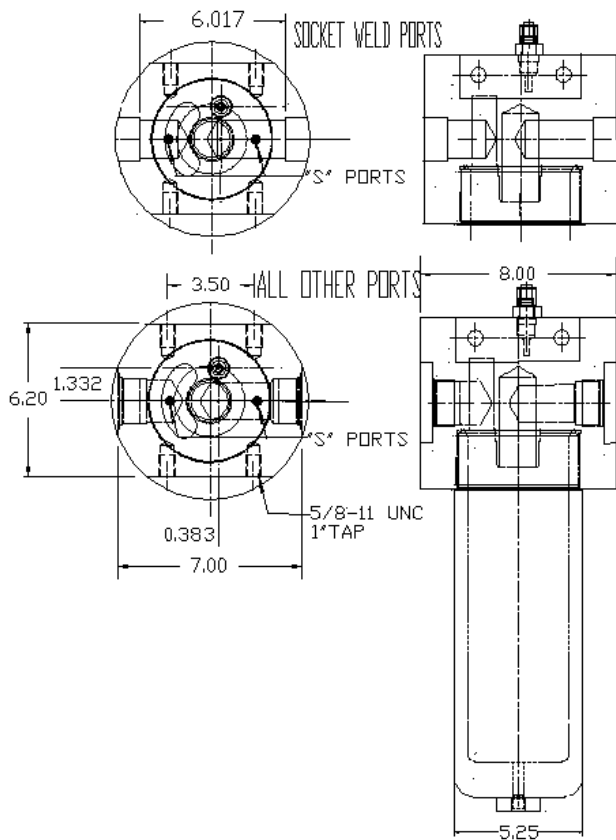

call now for
 more information
 708-233-5521

how to order

PRODUCT PART NUMBER 49 - - - -
 REPLACEMENT ELEMENT 549 - - - -

PORT SIZE & TYPE	
98	1" NPT
88	1.25" NPT
24	1.5" NPT
32	2" NPT
76	1" SAE
80	1.25" SAE
78	1.5" SAE
32A	2" SAE
STAINLESS STEEL ONLY	
16S	1" SOCKET WELD
20S	1.25" SOCKET WELD
24S	1.5" SOCKET WELD
TUBING SOCKET WELD PORTS ARE SPECIAL ORDER	

HOUSING	
A	ALUM.
G	S.S.
T	316 S.S.

ELEMENT CODE	
A	CELLULOSE
F	GLASS FIBER
G	STAINLESS MESH
R	RANDOM M.F.

MICRON RATING						
CODE	NOM	ABS	G	A	F	R
2X	2	10	●			
B1		1			●	
B3		3			●	
03	3	10		●	●	
05	5	18		●	●	
B5		5			●	
10	10	25		●	●	
B10		10			●	
20	20	40		●		
25	25	40			●	
B25		25			●	
40	40	75		●		
100	100	200		●		
200	200	300		●		

"O"RING MATERIAL	
L	BUNA-N
N	VITON
E	ETHYLENE PROPYLENE
MN	TEFLON COATED VITON
K	90 DUROMETER NITRILE
H	KALREZ™

COLLAPSE RATING	
R	300# CELLULOSE
A	300# GLASS FIBER
C	3200# GLASS FIBER
D	4500# STAINLESS MESH
E	4500# RANDOM M.F.

OPTIONAL ACCESSORIES	
DR1	1/8" NPT BOWL DRAIN
DR2	1/4" NPT BOWL DRAIN
DR3	1/8" SAE BOWL DRAIN
DR4	1/4" SAE BOWL DRAIN
S1	1/8" NPT D/P PORT
S2	1/4" NPT D/P PORT
S3	1/8" SAE D/P PORT
S4	1/4" SAE D/P PORT
V	VISUAL INDICATOR
EE	ELECTRICAL INDICATOR
R	BYPASS VALVE

4900 10/09

Oil & Gas • Aerospace • Power Generation • Alternative Fuel • Industrial • Elements • View Catalogs • Quality • Home • Contact Us

9850 S. Industrial Drive Bridgeview, IL 60455
 Phone: 708-233-5521 Fax: 708-430-5961
 Email: Sales@NormanFilters.com